



\* Intrinsically safe control circuit [EEx ia] IIC

**OPERATION**

**Operation without lead breakage monitoring**

	INPUT	OUTPUT
link between terminal 4 and 5	<p>0-Signal</p>	<p>relay energised</p>
link between terminal 4 and 5	<p>1-Signal</p>	<p>relay de-energised</p>
link between terminal 3 and 4	<p>1-Signal</p>	<p>relay energised</p>
link between terminal 3 and 4	<p>0-Signal</p>	<p>relay de-energised</p>

**Option with lead breakage monitoring**

The residual current flow of  $\geq 100 \mu\text{A}$  in the control, circuit is monitored by supplementary circuitry. In the event of a reduction in this current by, for example, control lead breakage, the relay is deenergised. When mechanical contacts are used, a resistor of approximately 10 kOhm must be connected in parallel directly across the contacts.

	INPUT	OUTPUT
without links	<p>10k</p> <p>0-Signal</p>	<p>relay energised</p>
without links	<p>10k</p> <p>1-Signal</p>	<p>relay de-energised</p>
without links	<p>10k</p> <p>0-Signal</p>	<p>relay de-energised</p>
without links	<p>10k</p> <p>1-Signal</p>	<p>relay de-energised</p>

**TECHNICAL DATA**

**Power supply**

supply voltage	198..253 V AC, 45..65 Hz
power consumption	approx. 3.5 VA

**Inputs (intrinsically safe) nominal values DIN 19234 or Namur**

quiescent voltage $U_{A0}$	approx. 8 V DC
short circuit current $J_{AK}$	approx. 8 mA
switching point $J_S$	within the range 1.2..2.1 mA
switching hysteresis $J_H$	approx. 0.2 mA
input pulse length / pulse interval	$\geq 0.5$ ms
lead breakage monitoring	$J \leq 100 \mu\text{A}$

**Details of certificate of conformity PTB Nr.Ex-79/2043X**

voltage $U_0$	max. 13.5 V DC
current $J_K$	max. 31 mA
power $P_{max.}$	max. 125 mW

**Permissible circuit values**

	[EEx ia]	[EEx ib]
ignition protection class, category	[EEx ia]	[EEx ib]
explosions group	IIB / IIC	IIB / IIC
max. external capacitance	929 nF / 230 nF	2929 nF / 609 nF
max. external inductance	5 mH / 3 mH	115 mH / 31 mH

**Output (non intrinsically safe)**

relay outputs	1 changeover contact
contact loading AC	250 V / 4 A / 500 VA / $\cos \varphi = 0.7$
contact loading DC	220 V / 0.1 A ; 60 V / 0.6 A ; 24 V / 4 A
mechanical life span	$10^7$ switching actions
pull in / drop out delay	Approx. 10 ms / approx. 20 ms

**Transfer characteristics**

max. switching rate	10 Hz
---------------------	-------

**Environmental conditions**

temperature	-25..60°C
protection class	IP 20
weight	0.4 kg

**Certification**

PTB (FRG)	Nr. Ex-79/2043X
GL (FRG)	94945 HH 9/80
ASEV (Switzerland)	Nr. 90.1 02719X
BASEEFA (GB)	No. Ex 80244 X
LCIE (France)	N° 79.2074 X
FM (USA)	J.I.OFOA6.AX (3610)
CSA (Canada)	LR 36087-2
SAA (Australia)	No. Ex 607

**Mechanical**

construction	modular housing NORYL SE 0 (self extinguishing), flammability class to UL 94: V - 0
mounting	by clipping onto 35mm standard rail to. DIN EN 50022 or by screw fixing.
method of connection	self opening instrument terminals; max. conductor cross sectional area 1 x 2.5 mm <sup>2</sup>

**TERMINAL ASSIGNMENT**

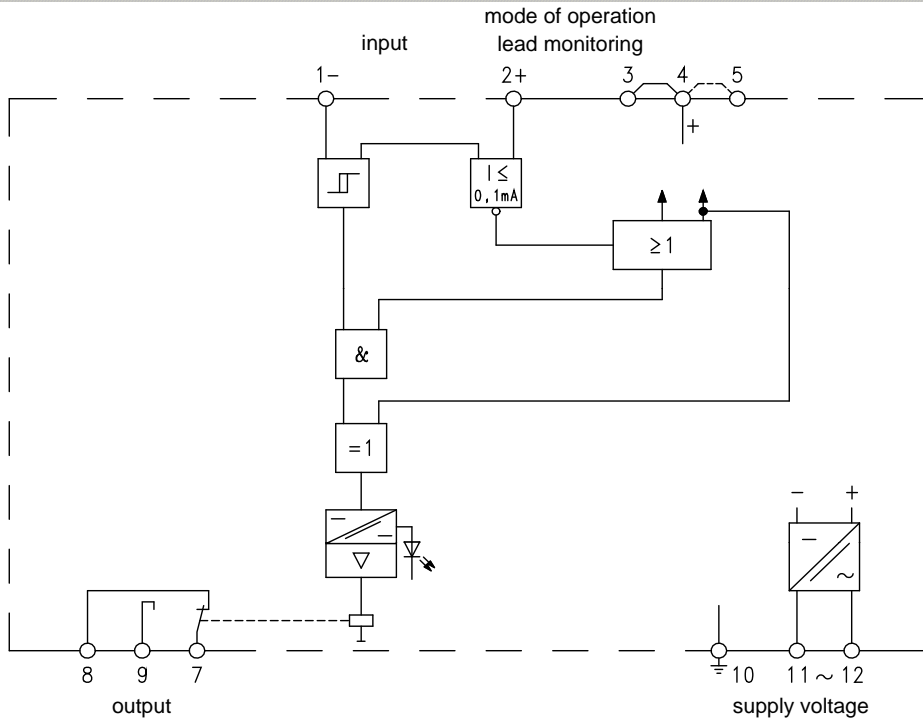

**DIMENSIONS**

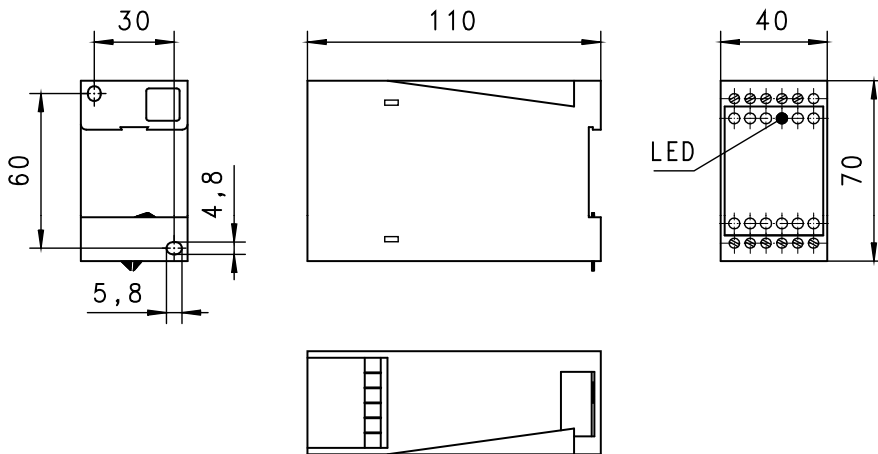

**NOMENCLATURE**

WE77/	Ex1	basic type specification
WE77/		● Isolated Switching Amplifier with relay output
	Ex1	● 1 - channel
	Ex2	○ 2 - channel

All technical changes reserved

●BASIC Standard ○BASIC Programme option □VARIO Special option ⊕ PLUS Accessories

✗ not recommendable