

GENERAL CHARACTERISTICS

Instruments operate by a spring-supported paddel with magnetic triggering of a reed switch.

- * good repeatability
- * low pressure loss
- * dirt resistant
- * hermetic separation of electrical and hydraulic components
- * easy adjustment of switch

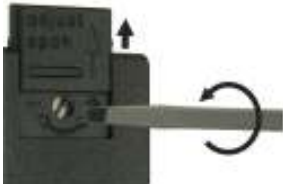

Solder fitting DN 10-40 copper



UR3K-032TC029

TECHNICAL DATA

	DN	Type	PN bar	Qmax. recom. l/min H ₂ O	adjustable range l/min H ₂ O	d mm	H mm	L mm	weight kg
copper	10	UR3K-010TC060	16	10	4.5 - 6	12	84	36	0.30
	12	UR3K-012TC100	16	14	7.5 - 10	15	84	40	0.30
	16	UR3K-016TC140	16	24	11 - 14	18	86	44	0.30
	20	UR3K-020TC210	16	40	16 - 21	22	86	50	0.30
	25	UR3K-025TC190	16	60	15 - 19	28	92	56	0.35
	32	UR3K-032TC295	16	100	23 - 29.5	35	92	64	0.35
	40	UR3K-040TC460	16	150	35 - 46	42	100	74	0.40

Adjustable range is indicated for horizontally decreasing flow.

tolerance	±15% of full scale (max.)
media temperature	max. 110°C
average pressure loss	0.01bar at Qmax.
hysteresis	depending on switch value minimum 0.7 l/min.

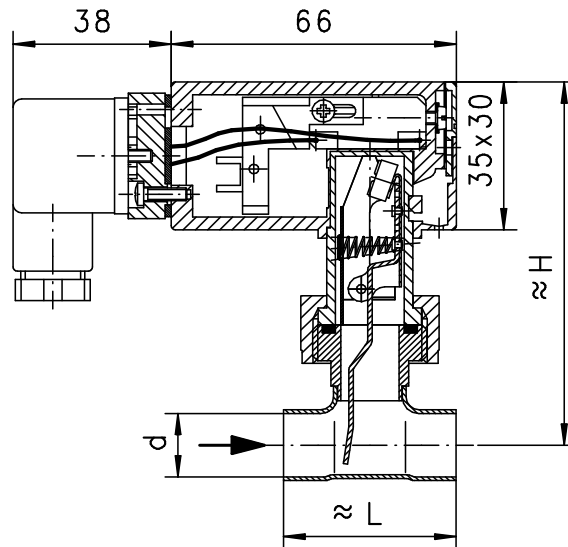

MATERIAL

housing	copper / brass Ms58
body	brass Ms58 nickel plated
paddel	stainless steel 1.4301 ; 1.4571
spring	stainless steel 1.4310
magnet	oxyd 300
seal	NBR

paddle

ELECTRICAL DATA

reed switch - wiring 0.372 n.o.
230 V AC 1A 50VA
plug DIN 43650-A
protection class 2
protection class IP 65

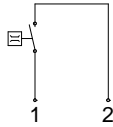

MOUNTING POSITION

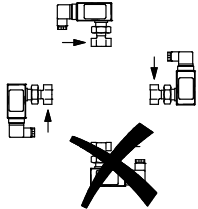

Installation position may influence switch value.

METERING SUBSTANCES



water



gas/air



oil

NOMENCLATURE

For combinations see table "technical data"

UR3K-	010	T	C	060		basic type
	010				●	specification
	012				●	DN 10 - Ø12
	016				●	DN 12 - Ø15
	020				●	DN 16 - Ø18
	025				●	DN 20 - Ø22
	032				●	DN 25 - Ø28
	040				●	DN 32 - Ø35
					●	DN 40 - Ø42
		T			●	solder fitting
			C		●	copper design
				060	●	4.5 - 6 l/min
				100	●	7.5 - 10 l/min
				140	●	11 - 14 l/min
				190	●	15 - 19 l/min
				210	●	16 - 21 l/min
				295	●	23 - 29.5 l/min
				460	●	35 - 46 l/min
Special option					□	setting / adjustable ranges for oil or gas
VARIO						contact for locking plug M12x1, 4-pole
						minimal flow range

IMPORTANT FOR YOUR ORDER

- Please indicate flow direction, metering substance and adjustable range with your order.
- With viscous liquids please indicate viscosity, temperature and metering substance (adjustable range on request)
- With gaseous media indicate pressure (relative or absolute), temperature and metering substance (adjustable range on request)

All technical changes reserved

●BASIC Standard ○BASIC Programme option □VARIO Special option ⊕ PLUS Accessories ✗not recommendable