

**GENERAL CHARACTERISTICS**

Instruments operate by a spring-supported paddle and contactless triggering of an inductive proximity switch.

- \* for liquids with ferrite contamination
- \* no magnetic wetted parts
- \* low pressure loss
- \* hermetic separation of electrical and hydraulic components
- \* good repeatability
- \* fixed switch value

Female thread G3/8 to G2 brass



UI-015GM060P

**TECHNICAL DATA**

	G	Type	PN bar	Qmax. recom. l/min H <sub>2</sub> O	switch value l/min H <sub>2</sub> O selectable range for fixed switch	H mm	L mm	X mm	weight kg
brass	G 3/8	UI-010GM040.	16	10	2 - 4	69	50	10	0.35
	G 1/2	UI-015GM060.	16	20	4 - 6	69	50	10	0.35
	G 3/4	UI-020GM080.	16	40	6 - 8	71	50	12	0.35
	G 1	UI-025GM170.	16	60	10 - 17	74	50	12	0.40
	G 1 1/4	UI-032GM270.	16	80	18 - 27	79	50	12	0.55
	G 1 1/2	UI-040GM370.	16	100	28 - 37	82	50	12	0.60
	G 2	UI-050GM550.	16	150	45 - 55	91	50	12	1.00

Switch value is indicated for horizontally decreasing flow.

tolerance	±5%
media temperature	max. 60°C
average pressure loss	0.01 bar at Qmax.
hysteresis	depending on switch value minimum 0.3 l/min.

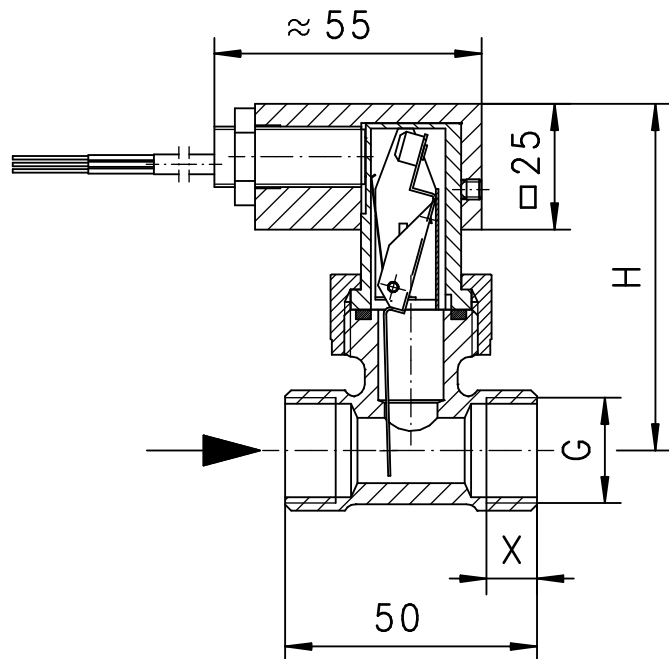

**MATERIALS**

housing	brass Ms58 nickel plated
body	POM glass-fibre
paddle	stainless steel 1.4301 ; 1.4571
spring	stainless steel 1.4310
seal	NBR
cap	POM

**ELECTRICAL DATA**

inductive proximity switch  
voltage range 10-30 V DC  
max. load < 10 mA  
max. current 100 mA  
voltage drop < 3V  
cable 2 metre, protection class IP 67

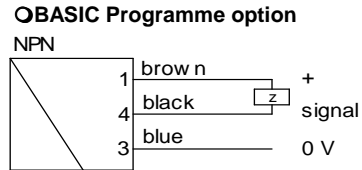
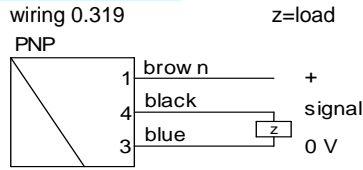

**MOUNTING POSITION**

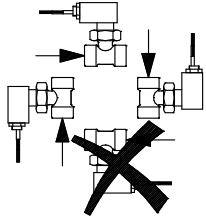

Installation position may influence switch value.

**METERING SUBSTANCES**

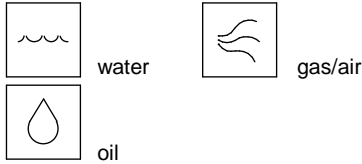

**NOMENCLATURE**

For combinations see table "technical data"

UI-	010	G	M	040	P		basic type specification
	010				●	nominal diameter	DN 10 - G3/8
	015				●		DN 15 - G1/2
	020				●		DN 20 - G3/4
	025				●		DN 25 - G1
	032				●		DN 32 - G1 1/4
	040				●		DN 40 - G1 1/2
	050				●		DN 50 - G2
		G			●		female thread
			M		●	brass design	
			K		○	stainless steel design	
				040	●	switch value selectable range	2 - 4 l/min H <sub>2</sub> O
				060	●		4 - 6 l/min H <sub>2</sub> O
				080	●		6 - 8 l/min H <sub>2</sub> O
				170	●		10 - 17 l/min H <sub>2</sub> O
				270	●		18 - 27 l/min H <sub>2</sub> O
				370	●		28 - 37 l/min H <sub>2</sub> O
				550	●		45 - 55 l/min H <sub>2</sub> O
					P	●	PNP output
					N	○	NPN output
Programme option					○		soldering socket type UI-...VM. (dimensions and switch values on request)
BASIC							
Special option					□		setting / switch ranges for oil or gas
VARIO							contact for locking plug M12x1, 4-pole

Installation position horizontal. Indicate switch value with your order.

**IMPORTANT FOR YOUR ORDER**

- Please indicate flow direction, metering substance and switch value with your order.
- With viscous liquids please indicate viscosity, temperature and metering substance (switch value on request)
- With gaseous media indicate pressure (relative or absolute), temperature and metering substance (metering range on request)

All technical changes reserved

●BASIC Standard ○BASIC Programme option □VARIO Special option ⊕PLUS Accessories ✗not recommendable